

# SA | Parting and grooving system

## Precision. Power. Process reliability.

Why SA? That makes the difference.

- ✓ **Cost savings of 70-90%**  
Longer service life, double-edged inserts without re-cutting up to Ø69 mm and no set-up times
- ✓ **Unique cooling technology (ACS)**  
We know of no more efficient and reliable cooling system on the market.
- ✓ **Fits your machine**  
Huge selection of suitable flange mounted holders for all common machine brands

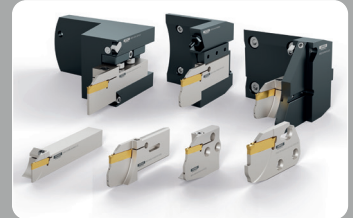

## ARNO COMPLETE SOLUTION

Everything from a single source. Perfectly coordinated. Proven for generations.



## ARNO ACS - UNIQUE INTERNAL COOLING

Patented. Unrivalled. Only at ARNO.

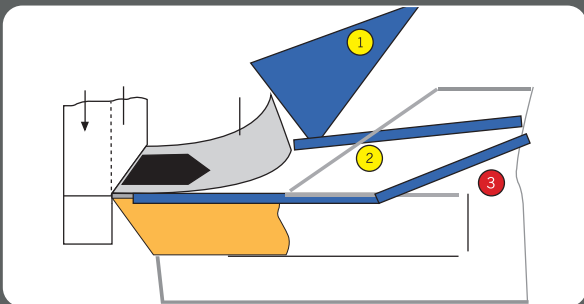

### COMPETITION

- ① External Cooling  
Scattering loss / Indirect cooling / Inefficient at depth
- ② Internal Cooling  
Scattering loss / cooling delayed / chip removal not optimal

③ **Internal Cooling (ARNO ACS)**  
Directly through the insert seat / 0% dispersion loss

### ACS – EFFICIENCY CHAMPION

- Coolant directly at the insert seat
- Optimal cutting zone cooling
- Ideal chip removal
- Targeted undermining of the chip

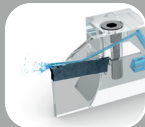

### ACS2 - OUR BEST

- Additional cooling of the tool flank from below: cutting zone cooling
- Even more control and performance in the process (longer service life and cutting parameters)



### ACS-3D - INNOVATION

- Additive manufactured module
- Dual cooling even with narrow modules
- Innovative triangular cooling channel for cooling the entire insert.



  
**Greater process  
reliability and control**

Up to  
**300 %**  
longer tool life in Ø  
after switching to SA.

## ARNO SERVICE – MORE THAN JUST TOOLS

The SA system is up and running. And if you have any questions, we are here to help. Immediately. Personally. With solutions.

### SUBSIDIARIES & PARTNERS

- Close to you globally
- 5 official subsidiaries
- Over 100 sales partners in many countries
- Continuous market monitoring and customer proximity



**95%**  
Tools in stock

### ARNO EXPORT TEAM

- Export team in Ostfildern
- Direct support for international customers
- Tools selection, processes optimization, orders & more
- Smooth global communication across borders



**9000**  
Deliveries per month

**<24h**  
Delivery for goods in stock

### APPLICATION TECHNOLOGY

- Experts in the most challenging machining tasks
- Where others give up – we get started
- On-site support and process optimization



**<0,1 %**  
Error rate in dispatch

## CURIOUS? - GET STARTED NOW

Please contact us directly.



„Users report up to three times longer tool life.“

„That one millimetre less can reduce costs by more than € 400,000 per year.“

„Increases of 400% are achievable.“

**Curious? - Click here for the press report**



Do you have any questions or want to get started right away?  
**Contact us directly. Free of charge and without obligation.**

Karl-Heinz Arnold GmbH  
Karlsbader Str. 4 | D-73760 Ostfildern  
Tel.: +49 (0)711 34 802 0  
Fax: +49 (0)711 34 802 130

export@arno.de  
anfrage@arno.de  
www.arno.de